

Flexible fix point supports

All-metal type

Stock no. 12000

Description:

- Mounting of flat design
- High static load capacity
- High dynamic load capacity
- High stability
- Resonant frequency: 15-20 Hz.

Material:

Housing:
Cast iron, black painted

All-metal cushion:
Stainless steel wire

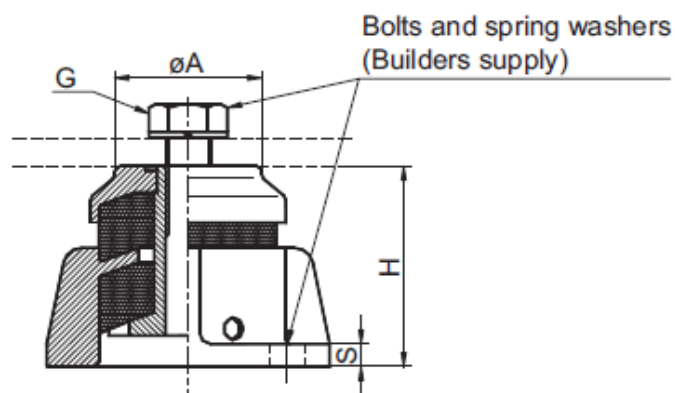

Mounting instruction:

All bolts must be secured with Loctite 620 or equal.
Loctite 620 is only usable by temperatures lower than 220° C.
Otherwise other alternatives must be used.
Mounting examples see previous pages

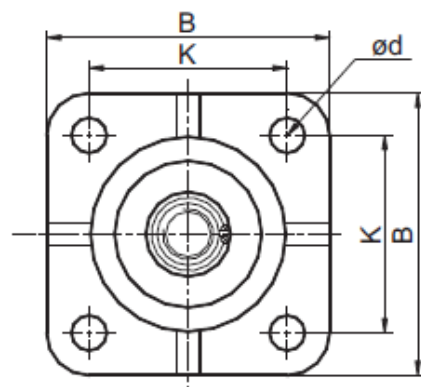

Bottom view

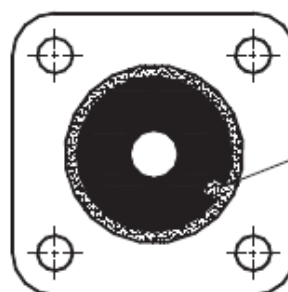

Align slot with hole in housing for using of fixing tool while tightening top bolt

Dimensions:

Type no.	Stock No.	øA [mm]	B [mm]	G	H [mm]	S [mm]	K [mm]	ød [mm]	Weight [kg]	Static load [daN]	Max. dyn. load [daN]	
											Compression	Tension
F 1212	12000-01-0012	35	80	M12	50	6	64	8,2	0,67	50 - 250	500	500
F 1216	12000-01-0016	52	100	M16	70	8	70	12,5	1,43	50 - 900	3500	3500
F 1218	12000-01-0018	60	130	M16	85	10	100	13,5	3,00	250 - 1500	6000	6000
F 1220	12000-01-0020	100	200	M20	100	10	152	17,0	9,20	500 - 2500	12500	12500
F 1227	12000-01-0027	100	220	M27	103	10	170	17,0	19,70	500 - 7000	22500	22500