

60° 1xD

Segment bend

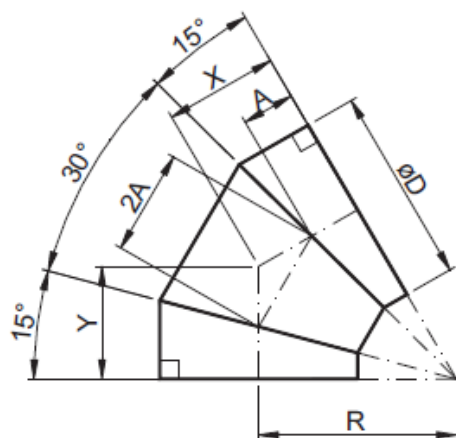

Stock no. 73060

Description:

- Pre-fabricated, welded 1xD segment bend with dimensions according to DIN 2605-1-60-2
- Other dimensions are available
- Tolerances according to DIN 1626.

Material:

- S235JRG2

Surface treatment:

- Standart is no surface treatment.
- Other surface treatment is available.

Stock No.	Nominal Diameter	Outer pipe dia. øD	Wall thickness S	Bending radius R	Length of segment A	Face to face dim. X=Y	Weight
	[ND]	[mm]	[mm]	[mm]	[mm]	[mm]	
73060-01-0300	300	323.9	4	305	82	176	10.5
73060-01-0350	350	355.6	4	356	95	206	13
73060-01-0400	400	406.4	4	406	109	234	17.5
73060-01-0450	450	457.0	4	457	122	264	22
73060-01-0500	500	508.0	4	508	136	293	27
73060-01-0550	550	559.0	4	559	150	323	33
73060-01-0600	600	611.0	5	610	163	352	49
73060-01-0650	650	660.0	5	660	177	381	57
73060-01-0700	700	711.0	5	711	190	411	67
73060-01-0800	800	813.0	5	813	218	469	87
73060-01-0900	900	914.0	5	914	245	528	110
73060-01-1000	1000	1016.0	6	1016	272	587	162
73060-01-1100	1100	1120.0	6	1120	300	647	198
73060-01-1200	1200	1220.0	6	1220	327	704	235

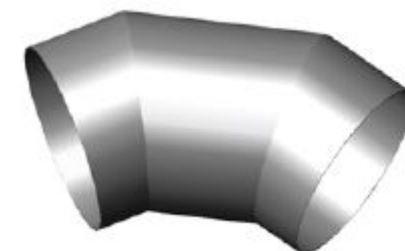

60° 1xD

Segment bend

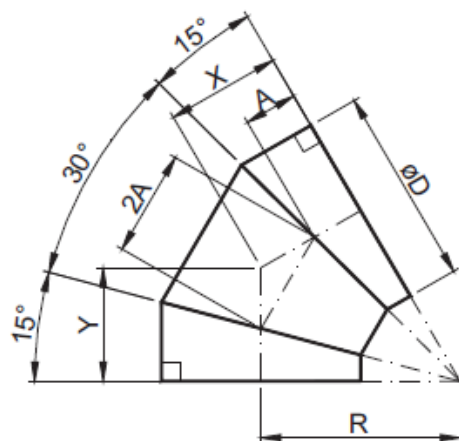

Stock no. 73060

Description:

- Pre-fabricated, welded 1xD segment bend with dimensions according to DIN 2605-1-60-2
- Other dimensions are available
- Tolerances according to DIN 1626.

Material:

- S235JRG2

Surface treatment:

- Standart is no surface treatment.
- Other surface treatment is available.

Stock No.	Nominal Diameter	Outer pipe dia. øD	Wall thickness S	Bending radius R	Length of segment A	Face to face dim. X=Y	Weight
	[ND]	[mm]	[mm]	[mm]	[mm]	[mm]	[kg]
73060-01-1300	1300	1320.0	6	1320	354	762	275
73060-01-1400	1400	1420.0	6	1420	380	820	318
73060-01-1500	1500	1520	6	1520	407	878	365
73060-01-1600	1600	1620	8	1620	434	935	552
73060-01-1700	1700	1720	8	1720	461	993	623
73060-01-1800	1800	1820	8	1820	488	1051	699
73060-01-1900	1900	1920	8	1920	514	1109	776
73060-01-2000	2000	2020	8	2020	541	1166	860
73060-01-2100	2100	2120	8	2120	568	1224	948
73060-01-2200	2200	2220	8	2220	595	1282	1038
73060-01-2300	2300	2320	8	2320	622	1340	1134
73060-01-2400	2400	2420	8	2420	648	1397	1235

